





Line Types

Working drawings contain lots of different line types. It is important to understand what each represents on a drawing.

	Continuous thick	Used for visible outlines and edges.
	Continuous thin	Used for projection, dimensioning, leader lines, hatching and short centre lines.
	Dashed thin line.	Used for hidden outlines and edges.
	Chain thin.	Used for centre lines, lines of symmetry.
	Chain thin double dash	Used for ghost outlines and bend lines.

Dimensions

The working drawings we will use in practical woodwork have three main types of dimension.

Linear Dimension - the width or length of a section

Radial Dimension - the radius of a curved section

Diameter Dimension - the width of a circular section or hole

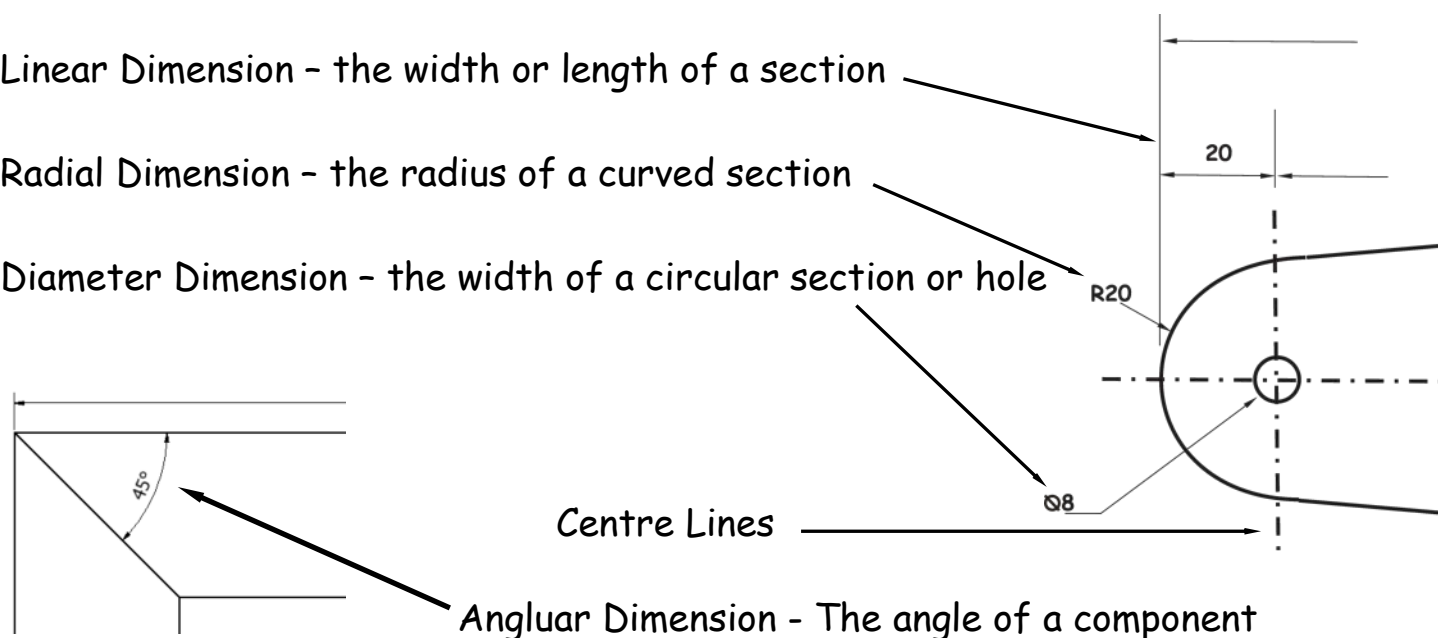

Boclair Academy

Technical Department



Practical Woodworking

Knowledge & Understanding

in Wood

Contents

	Page No
Safety	3
Knowledge & Understanding of Wood	7
Timber Supply	9
Wood types	8
Form of Supply	10
Man-made boards	11
Wood Joints	13
Surface Preparation & Finishing	17
Applying a Finish	19
Gluing and clamping up models	21
Woodworking tool	24
Drill Bits	34
Types of Planes	35
Sharpening Chisel/Blades	37
Machine Tools	38
Wood Turning	40
Fixings	43
Reading working Drawings	46

If we are drawing an object double its actual size (scaled up) we would put this at the bottom of the drawing informing people reading it that the object is half the original size:

Scale 2:1

What you are drawing



The Object

This means that for every 2mm drawn, 1mm of the actual object has been represented

Orthographic Projection

Working drawings are drawn using orthographic projection - this controls where each view of an object goes on the page. They are drawn as shown below. The **PLAN** is always located above the **ELEVATION** and the **END ELEVATION** is always located either side of the **ELEVATION**.

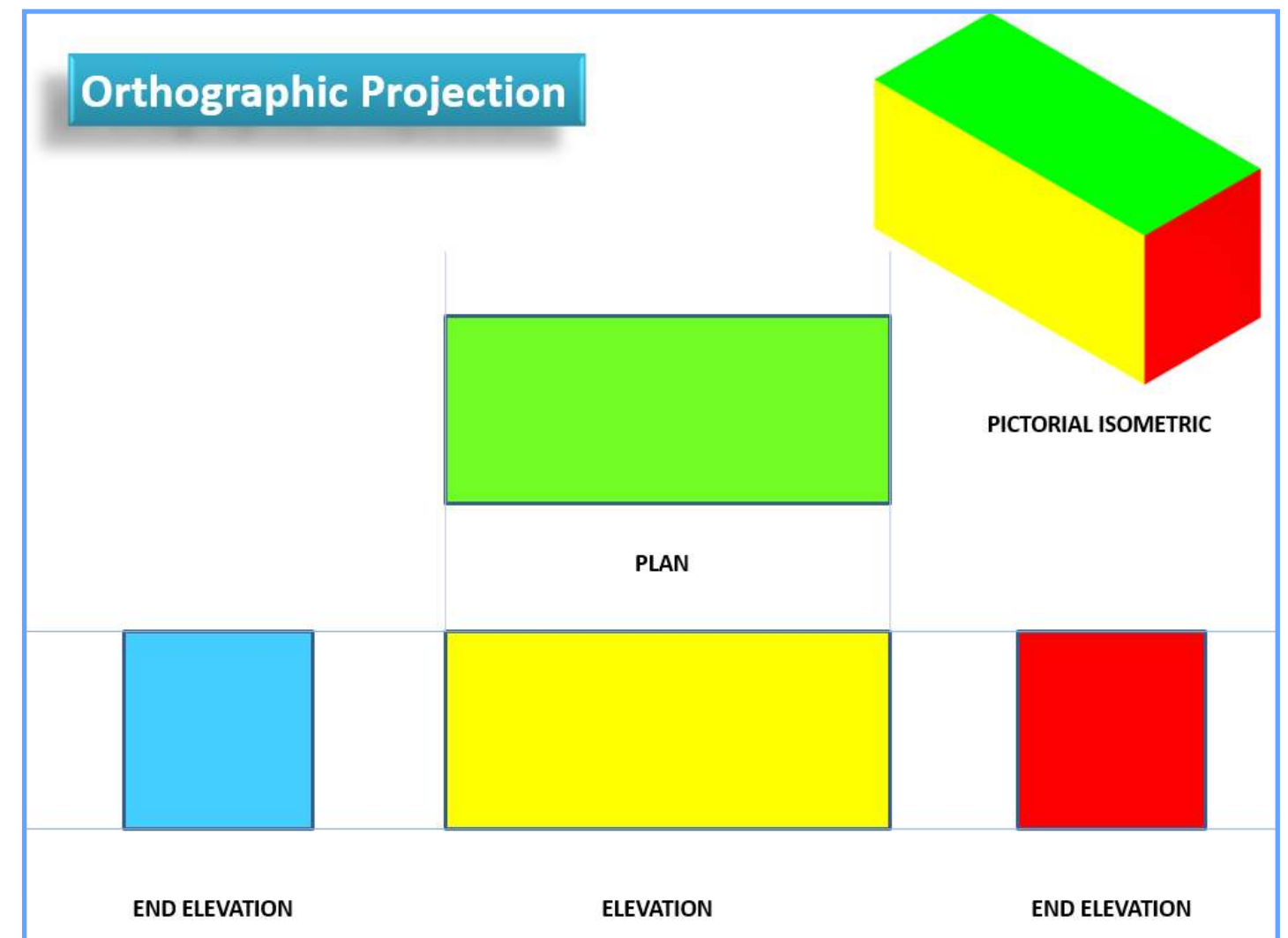

Reading Drawings

In Practical Woodworking we will come across two main types of drawing - working drawings and pictorial drawings. We need to be able to read drawings to enable us to make models for potential clients.



Pictorial Drawing

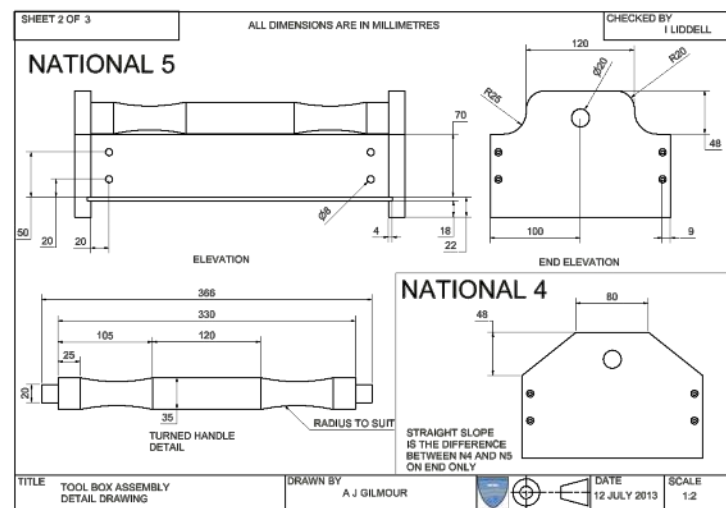

Orthographic Drawing

Scale

Working drawings are always drawn to a scale, this is a ratio which tells us what size the parts on the drawing would be in real life.

Identifying Scale

When we are scaling drawings we must indicate what scale we are drawing them to. So, for example, if we are drawing something *to scale* (which means that we are drawing it to its actual size) we would put this at the bottom of the drawing:

Scale 1:1

What you are drawing



The Object

This means that for every 1mm drawn, 1mm of the actual object has been represented

If we were to draw an object to half of its actual size (*scaled down*) we would put this at the bottom of the drawing informing people reading it that the object is half the original size:

Scale 1:2

What you are drawing



The Object

This means that for every 1mm drawn, 2mm of the actual object has been represented

Safety

Safety is of major importance in any craft room, it is imperative that safe working practices are observed at all times. Failure to observe safety rules will result in that individual losing the privilege to work in the craft room.

Some general safety precautions

1. Work benches and machines must always be swept clean after use. Think of the person who has to use them NEXT.
2. NEVER run when in the workshop, running causes accidents.
3. If sharp tools must be carried in the work shop they must be carried facing downwards.
4. ALWAYS work with sharp tools, blunt tools cause accidents.
5. Before any work commences all jackets should be removed and hung up. All bags placed under the workbench. Any loose cloth or hair should be tucked in or tied back.
6. Pupils should be familiar with the position and operation of the emergency stop buttons in workshops. ONLY press if an EMERGENCY arises.
7. Eye protection must be worn if operating any machinery.
8. Report any damaged tools, equipment, etc. to the teacher.
9. ALWAYS store tools in the well of the bench when not in use.
10. ALWAYS keep both hands behind the cutting edge when working with a chisel.
11. NEVER strike two hammer faces together. Flying metal chips could cause serious injury.

Workshop Safety (Continued)

12. ALWAYS use a file fitted with a handle, tangs are sharp and very dangerous if used without a handle. If you are unsure what a tang is, ask your teacher, after all that is why they are there.
13. ALWAYS check machines to ensure that any rotating parts are properly guarded and free to rotate without obstruction, e.g. ensure before switching on that the chuck key is removed from the Jacob's Chuck. Never use a machine without permission from the teacher.
14. Ensure machine guards are fitted and in the right positions.
15. Wear appropriate PPE (Personal Protective Equipment) and ensure hair is tied back and you are wearing no loose clothing that could become entangled in machinery.
16. Ensure machines working correctly before using.
17. Ensure drill bits etc. are inserted correctly into machines before using.
18. Ensure work is clamped securely before switching on machinery or power tools.
19. Ensure extraction is turned on where appropriate.
20. Ensure cables on power tools are not damaged before use.
21. Ensure machines and power tools are switched off or locked off before changing accessories, making adjustments, or storing the tool. Always remove keys and adjusting wrenches before turning the power back on.
22. Use a push stick to push material into the cutting area. Keep hands out of the line of the cutting blade.
23. Never leave a power tool or machine running when not being used.

Knock Down Fittings

Modesty Block/Corner Block

KD fittings are ideal for use with furniture which are flat packed or have to be taken apart and re-assembled at a later date. There are many different types. The images opposite are an example of one. It shows how a **Modesty Block/Corner Block** is being used to connect two pieces of wood together right angles.

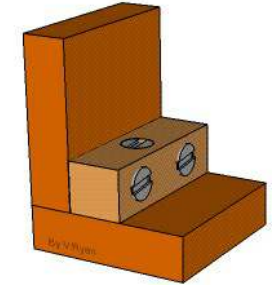
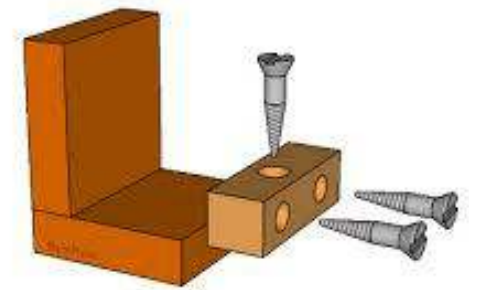

Cam Lock

This type of fitting uses a screw with a specialised head. The screw is turned into the wood. The specialised head is located into the cam fitting. On turning the cam it draws the head further into it, tightening the joint.

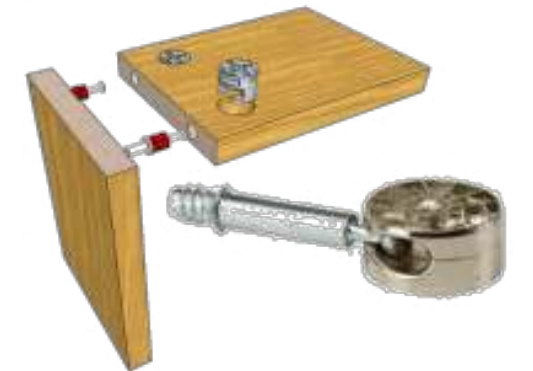

Cross Dowel

In this fitting the **Cross Dowel** is inserted into a hole in the wood as shown. The screw is then put through the components which are to be fitted together. It then locates the thread in the Cross Dowel and pulls the two components together.



Cross Dowel



Corner Angle Bracket

This bracket is very similar to the modesty block at the top of the page. It simply joins two components together at right angles using screws.



Round Head Screw

These screws are used to screw thin metal fittings to wood e.g. Tee Hinges, etc. They are used for jobs which do not require the head to be flush. They are made of steel and usually come "Black Japaned". (A black coating to prevent rusting)

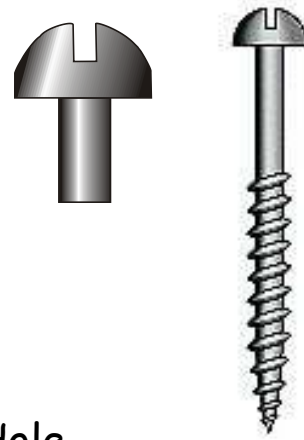

Countersink Screw

The main purpose of the countersink screw is that when fully engaged the head of the screw will sit flush with the surface of the material in which it has been used.

When joining two pieces of wood together the top piece of wood will have a clearance hole drilled first. This hole will be slightly larger than the actual diameter of the screw.

A countersink hole is then drilled as can be seen from the picture shown below. This is the hole in which the head of the screw will sit when fully engaged.

Finally, a pilot hole is drilled. This allows the screw threads to get started. In soft wood a Bradawl could be used.

Soap or wax can also be used on the threads as this will lubricate them allowing easier turning.

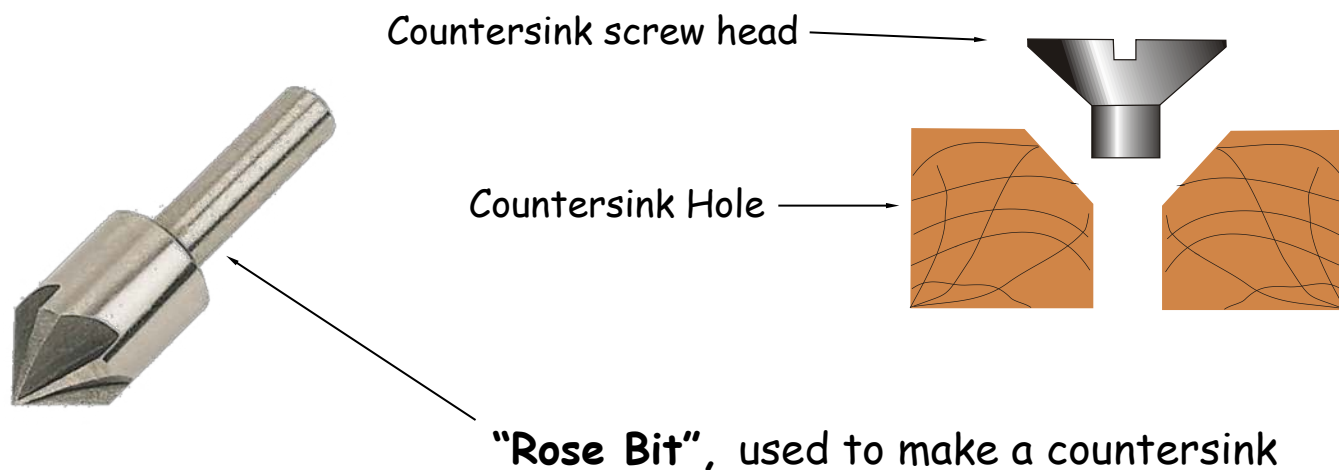
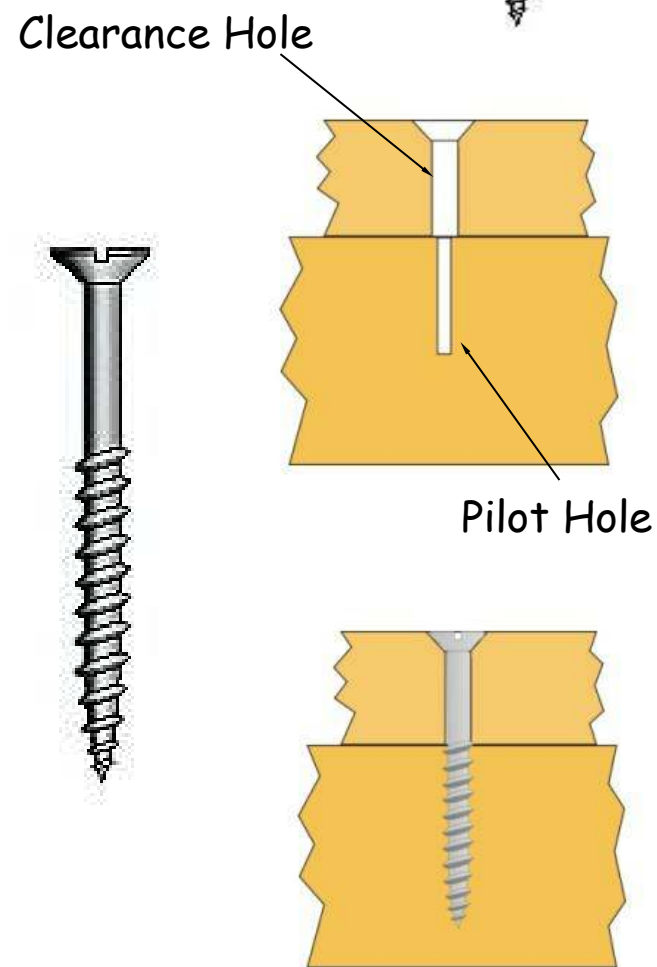

24. Ensure that the tools are properly grounded using a three-prong plug, are double-insulated or are powered by a low-voltage isolation transformer, this will protect users from an electrical shock.
25. Keep your work area free of clutter and debris that could be tripping or slipping hazards.
26. Ensure others are clear of machine area before using.
27. Warn to others nearby when using chisels and power tools.

The Workshop is a Safety Zone



PPE (Personal Protective Equipment)

The following equipment must be used when carrying out the activities which could damage area of the body if not worn.



Full Face Visor
Eye/face protection



Prevent inhalation
of toxic substances



Safety Glasses
Eye protection



Ear Muffs
Ear protection



Safety Gloves
Hand protection



Apron
Body protection

When the following signs are seen in a workshop the appropriate PPE should be worn;



Safety Glasses



Full face visor



Ear Muffs



Safety Clothes



Dust Mask



Safety Gloves

Fixings

Panel Pin

This type of nail has a thin round shank and a small head which can be driven below the surface with a nail punch.

The standard sizes available are from 12mm to 50mm in length.



Oval Brad

This nail has an oval shaped shank (long part of the nail). It is shaped this way so as to allow it to be driven below the surface of the wood without splitting it. As can be seen in the sketch opposite the nail is positioned length ways along the grain.

Wood Grain

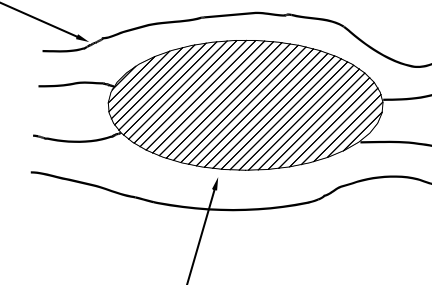

Cross Section (Cut through)
of Oval Brad nail



Round Wire Nail

These nails have a flat head and are made from steel. They are sometimes Galvanised (Dipped in Zinc) to stop them from rusting. They are used for general joinery work and normally come in sizes ranging from 12mm to 150mm.



Raised Countersunk Head Screw

These screws are not very common but are used to screw fittings to wood. They are often made from chrome plated brass which gives an attractive finish.

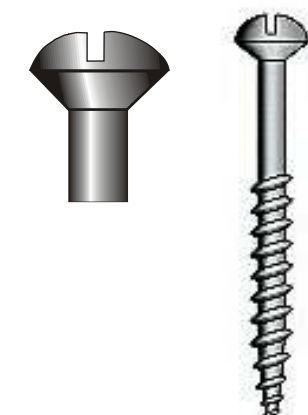

Stages in preparing a piece of wood for turning

Stage 1

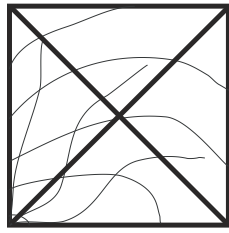

On both ends of wood mark a line from corner to corner to establish the centre.

Stage 2

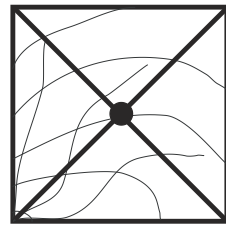

On one end of the wood, using a centre punch, make a hole. The Cone Centre will locate here.

Stage 3

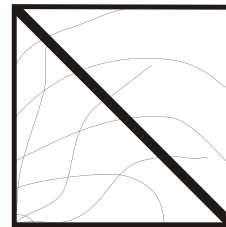

On the other end cut a Kerf. The Centre Fork will locate here.

Stage 4

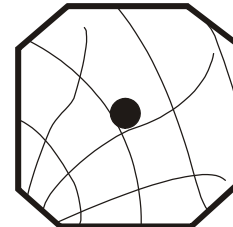

Now plane all four corners of the wood as can be seen from the sketch above.

Face Plates

Face plates are secured to the headstock of the lathe and are used to hold blank pieces of wood which can then be turned into wooden bowls.

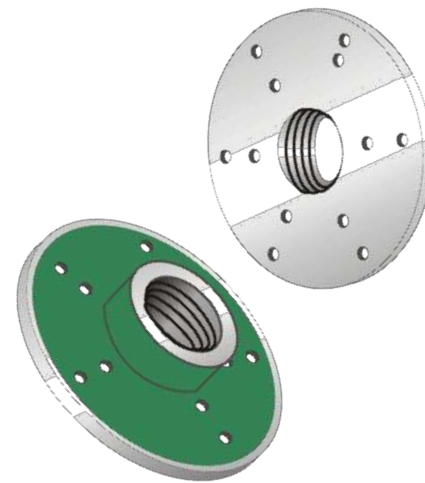

Mortise Chisel

Mortise Machine

A mortise machine appears to drill a square hole in wood. The machine actually drills a round hole but because the drill bit is surrounded by a hollow square chisel, while the drill is creating the hole, the chisel is cutting the edges away from the hole leaving the mortise. (square hole)



Knowledge and understanding of Wood

Throughout the world there are thousands of different species of tree, adding beauty and colour to our surroundings. They help keep the air fresh by taking in carbon dioxide and giving out oxygen. When cut or felled, and properly seasoned, the wood they provide has many uses including boat construction, house building, furniture and of course a wide variety of articles made in the school classroom.

Grain

All timber is composed of cells and wood fibres packed closely together. The term "grain" refers to the arrangement or direction of the cells and fibres in the timber. Try to imagine holding a bunch of drinking straws, this is basically very similar to how the grain of wood would look like if we looked at it through a microscope.



Classification of Wood

Trees are classified into two main groups, **Hardwoods** and **Softwoods**.

Hardwoods

This group of trees have broad flat leaves and seeds enclosed in a fruit or seed case. Hardwoods can be deciduous or evergreen. A tree which loses its leaves in the Autumn is called a deciduous tree. Examples of hardwoods are, Beech, Oak, Ash, Mahogany, Teak, Hickory.



Softwoods

This group of trees have long needle-like, shaped leaves and seeds exposed in cones and are known as conifers. Most softwood trees are evergreen (i.e. they keep their leaves all year round). Examples of softwood are, Red Pine, White Pine, Cedar, Douglas Fir.



Softwoods



Red Pine - Cheap, light weight, easy to work with. Used in construction.



Larch - Heavy, hard, good water resistance. Easy to work with. Used for floors and construction.

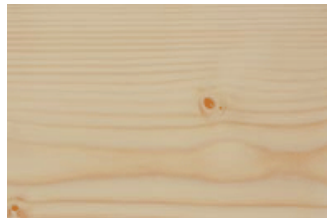

White Pine - Cheap, light weight, easy to work with. Used for construction, fencing, external cladding and flooring.



Cedar - Medium weight, low strength, good water resistance. Used furniture and veneers.

Hardwoods



Beech - Hard and heavy. Good for machining. Used for furniture, ladders, sports equipment and tool handles.



Mahogany - Strong, good water resistance. Easy to work with and machine. Used for furniture and veneers.



Oak - Heavy, hard and strong. Used for barrels. Expensive.



Ash - Expensive, strong. Used for furniture and veneers

Drive Fork

The drive fork is secured in the revolving spindle (headstock). The fork is driven into the wood to be turned, the fork then turns the wood. A typical example is shown opposite.



Parting Tool

The parting tool as it's name implies is used to part off the "turned wood" from the remaining wood at either end.

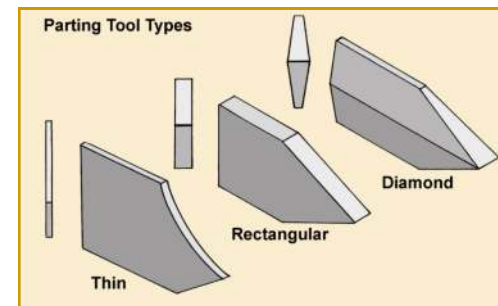

Spindle Gouge

This round nosed gouge takes over from the roughing-out gouge for general between centre turning.



Round Scraper

These scrapers are used for working inside bowls and goblets.



Skew Chisel

This chisel is used to give a good surface finish.



Wood Turning Lathe



The wood lathe is a machine used to create cylindrical objects in wood, i.e. wooden bowls, table legs, etc. A piece of wood is secured between two points called the HEADSTOCK and the TAILSTOCK. The HEADSTOCK has a motor enclosed and is therefore the end which actually turns the wood.

The surface finish of the wood being turned can be improved by increasing the speed of the lathe.

Wood Turning Tools

Wood turning tools are used to shape the work piece. Depending on what shape is required will ultimately determine what type of tool will be used. The tool rest can be seen on the drawing above, this is used to support the tools while shaping is being carried out.

Revolving Centre

The Revolving Centre has bearings encompassed within the body of the tool. This allows the work piece to revolve without friction.



Dead Centre

The tailstock remains stationary while the work rotates. This causes friction and therefore the work piece has to be greased.

Timber Supply

Timber comes from cut down trees which have been loaded onto large vehicles and then transferred to the saw mills.

It is then cut into its various forms using either a "Through and through" method or a "Quarter" cut method as can be seen below.



Unfortunately due to its high water content timber cannot be used straight from a tree. It has to be kiln dried first.

The kiln consists of a sealed container with a heater, vent and air circulator.

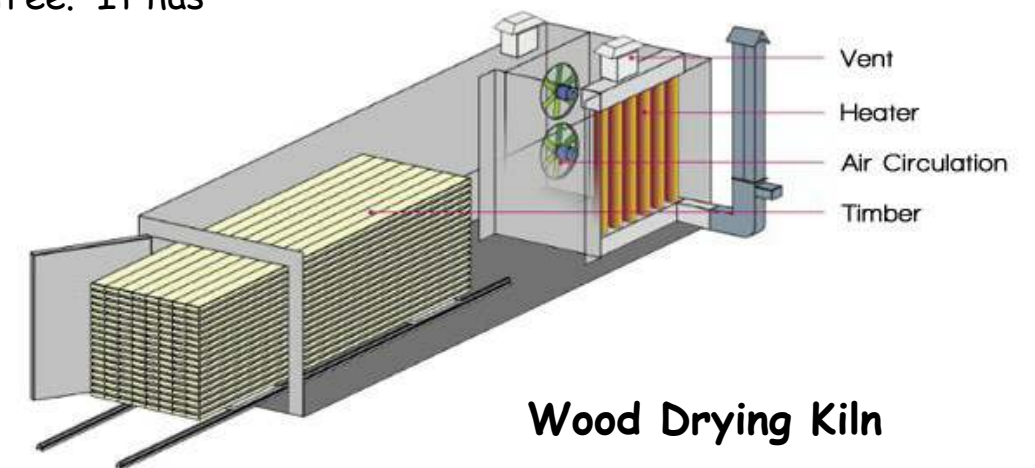

Wood Drying Kiln

Through & Through Sawn

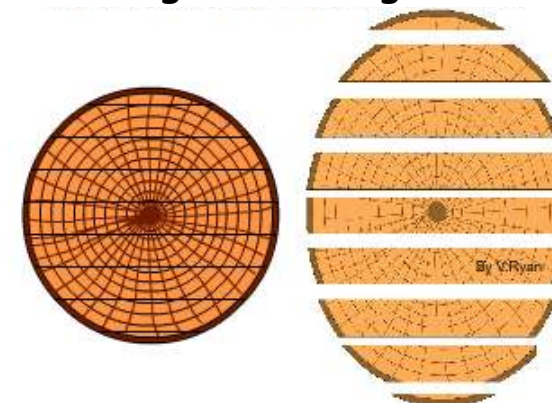

Quarter Sawn

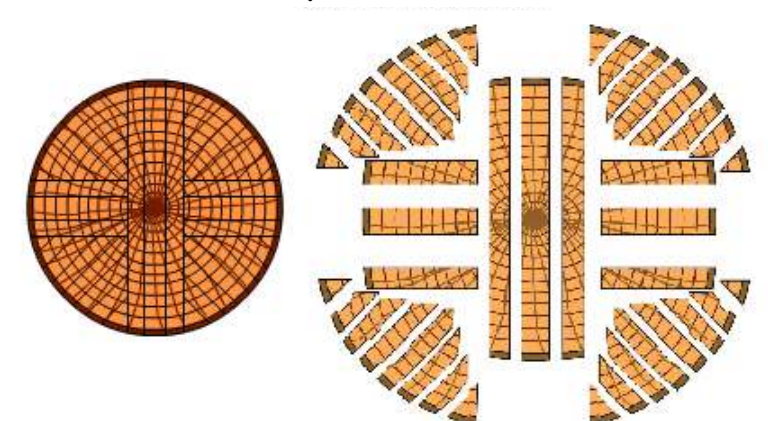

Timber - Form of Supply

Timber is usually supplied in the following sections.

Planks Vary from 38mm to 100mm in thickness and over 100mm in width.



Boards Less than 38mm in thickness and over 100mm in width.



Strips Less than 38mm in thickness and less than 100mm width.



Squares Square Section - thickness same as width.



Dowel Rods Dowel Rods, or cylindrical wooden pegs, are variable in sizes from 3mm to 50mm. Common timber used for dowel rods are Ramin or Beech.



Disk Sander

A disc sander is most commonly implemented as a stationary machine that consists of a replaceable circular shaped sandpaper attached to a wheel turned by an electric motor.



Cordless Screwdriver

A cordless screwdriver is a power tool used to set or remove screws or other threaded fasteners. They have interchangeable tips that fit into a socket on the end of the shaft and are held in mechanically or magnetically.



Cordless Electric Hand Drill

A cordless drill is a tool fitted with a cutting tool attachment or driving tool attachment, usually a drill bit or driver bit, used for boring holes in various materials or fastening various materials together with the use of fasteners. They are powered by Batteries usually up to 24V.



Corded Electric Hand Drill

A corded drill is a tool fitted with a cutting tool attachment or driving tool attachment, usually a drill bit or driver bit, used for boring holes in various materials or fastening various materials together with the use of fasteners. They are powered by 240V mains electricity.



Jigsaw

A jigsaw power tool is a jigsaw made up of an electric motor and a reciprocating saw blade. A jigsaw with a bevel function on the sole plate allows cutting angles of typically up to 45 degrees relative to the normal vertical stroke for cutting mitre joints.



The Pillar Drill

The pillar drill (or Vertical Drill) can either be bench mounted or floor mounted. The chuck (part which holds the twist drill) can hold drills up to a 13mm diameter. The adjustable table which holds the work piece can slide up or down and can be locked at a desirable height.



Safety Check

Before Drilling - ensure the drill is secure with the chuck key removed (where applicable), eye protection on, guard in position and work piece securely held.

Orbital Sander

Random orbit sanders are hand-held power tools for sanding in which the sanding blade delivers a random-orbit action. That is, the angle of rotation of the head and disk is variable. Random-orbital sanders use sandpaper disks, and many include integrated dust collectors.



Upright Belt Sander

Belt sanders can have a very aggressive action on wood and are normally used only for the beginning stages of the sanding process, or used to rapidly remove material. Sometimes they are also used for removing paints or finishes from wood.



Hand Held Belt Sander

This sander is very similar to the upright belt sander but has the benefit of being portable.



Man-made boards

Very wide boards (cut timber) made of hardwood or softwood are rare, expensive and liable to warping. They are in short supply because many of the world's rain forests are disappearing due to the over cutting of trees. Wide boards can be made by butt joining narrow boards together but this is time consuming and can also warp. One way which has overcome this problem is the development of man-made boards. These boards are generally very strong although some are stronger than others, depending on how they have been made. There are many different types of man-made board available and among the more common are PLYWOOD, BLOCKBOARD, CHIPBOARD, MDF and HARDBOARD

Plywood

This is made from layers or plies of wood glued together so that the grain of each layer of ply is at right angles to the next. There is always an odd number of plies (layers) so that the grain runs the same way on both sides of the board. Plywood can be finished with a decorative hardwood veneer or melamine (thin plastic coat)



Blockboard

These are made by sandwiching strips of softwood between two plies. As with the plywood the strips of softwood run at right angles to the top and bottom plies. It can also be finished with a hardwood veneer. It is only suitable for interior use.

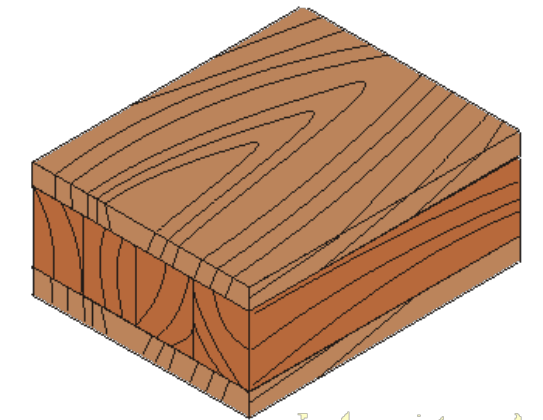

Chipboard

Chipboard is made by gluing small wood chips together under heat and pressure. As with blockboard it is only for interior use. Examples of chipboard use are kitchen work tops which generally have a melamine-faced finish.



Hardboard

This is made by mixing wood fibres with water and synthetic resin glue, hot pressing it into sheets and leaving to dry. It is not very strong and is generally only used internally.



MDF (Medium Density Fibreboard)

This is made in a similar way to hardboard but is much thicker. It has a smooth surface that takes paint and varnish very well and makes an excellent ground for veneers.



Finishing

Finishing is the name given to the process of coating or sealing wood. This is what gives the surface of the wood its final finished appearance. There are a wide variety of finishes available and depending on the final use of the wood will most likely determine what finish will be applied.

If a coffee table was made in the school workshop and a final finish was not applied to the surface, what do think would happen to the wood if coffee or tea was spilt on it?

Firstly, the fluid would soak into the wood, staining it and most likely through time weakening the wood by swelling it.

Honing a Chisel (Sharpening)



Oil Stone



Oil Stones are used to sharpen chisel blades

Flatten the bottom of the **chisel** by holding it flat to your **sharpening** stone and working it back and forth lengthwise in a figure of eight configuration. on coarse, then medium, then fine grits of stone. Sharpen the bevel with the **chisel** face down on its bevel. Draw it back and forth on the coarse/medium/fine stones without tipping it. As can be seen above, a **Jig** can be used to get the correct angle.



Honing a Jack Plane Blade (Sharpening)

The method here is very similar to the sharpening of a chisel except the angle the blade is held at will be different.



The diagram below shows what a well sharpened blade should look like.

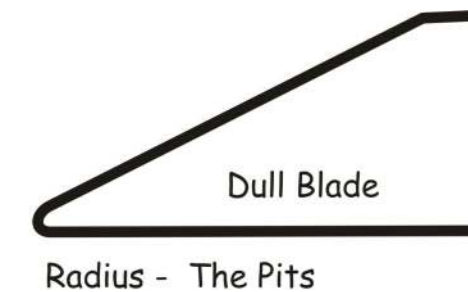
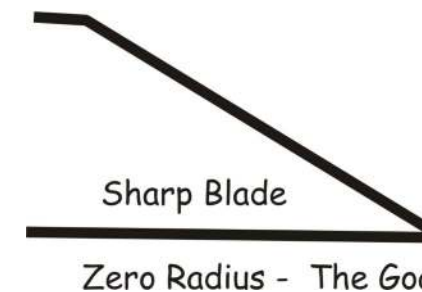

Router Plane (*Granny's Tooth*)

This plane is used for trimming the bottom of housing joints to the correct depth.



Block Plane

The block plane is used for trimming the end grain, mitres or interlocking grain depths.



Plough Plane

The plough plane is used for ploughing grooves parallel to an edge. It must be used with the grain i.e. in the same direction in which the grain runs.



Typical cut made by a Plough Plane



Spoke Shave

This type of plane is used to smooth curves. There are two types available; one for concave surfaces and one for convex surfaces.



Bullnose Rebate Plane

Used in forming stopped rebates and chamfers. It could be described as the



Timber Joints

The majority of joints used in woodcraft have been designed specifically to attain the maximum possible strength in the model they are holding together. The type of joint selected will depend on what is being constructed i.e. what forces are going to be exerted upon the artefact. The selection is also dictated by the final appearance. i.e. in furniture manufacture it is normally important to hide the joint as a piece of furniture which has a joint construction which is strong but showing will not be very pleasing to look at and ultimately potential customers would most likely avoid buying such furniture.

Flat Frame Joints

Butt Joint

Butt joints are the quickest and simplest to make but are not very strong. They generally need dovetail nailing to increase the overall strength of the joint. Also used in Carcass construction.

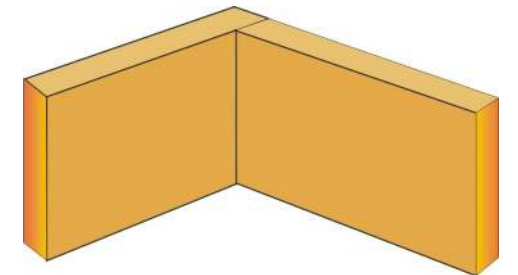

Dowelled Joint

These joints are both neat and strong. The holes must be lined up exactly but this can be done using a dowelling jig. The dowel will have a groove in the length so as to allow excess glue to escape. Also used in Carcass construction.

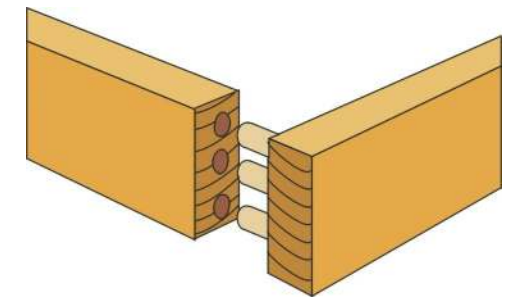

Haunched Mortise & Tenon Joint

This joint is used where the rail of a table join into the top leg of the table. This could be regarded as a hidden joint.

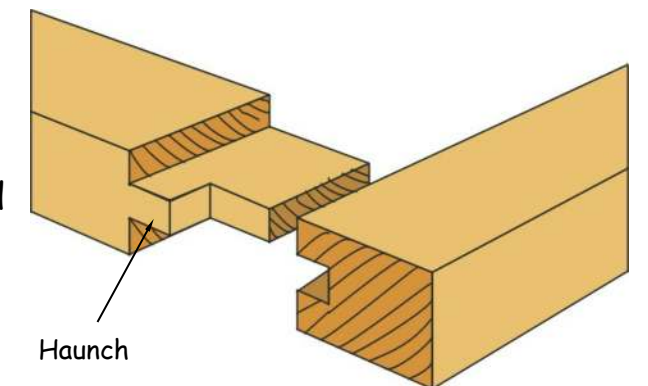

Corner Halving Joint

This joint is stronger than the butt joint and is also simple to make, but still needs strengthening with screws or dowels.

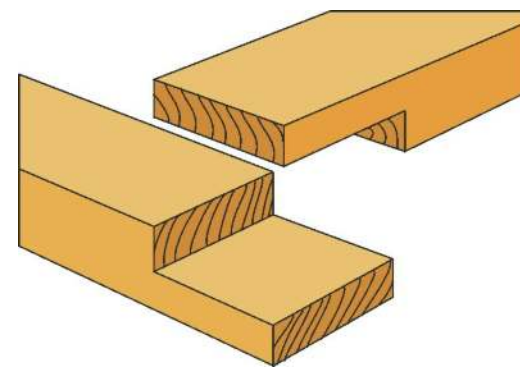

Mitre Joint

A joint made by bevelling each of two surfaces to be joined, usually at a 45° angle, to form a corner, usually a 90° angle. The joint on its own is not the strongest but this can be reinforced by apply some of the following to it.

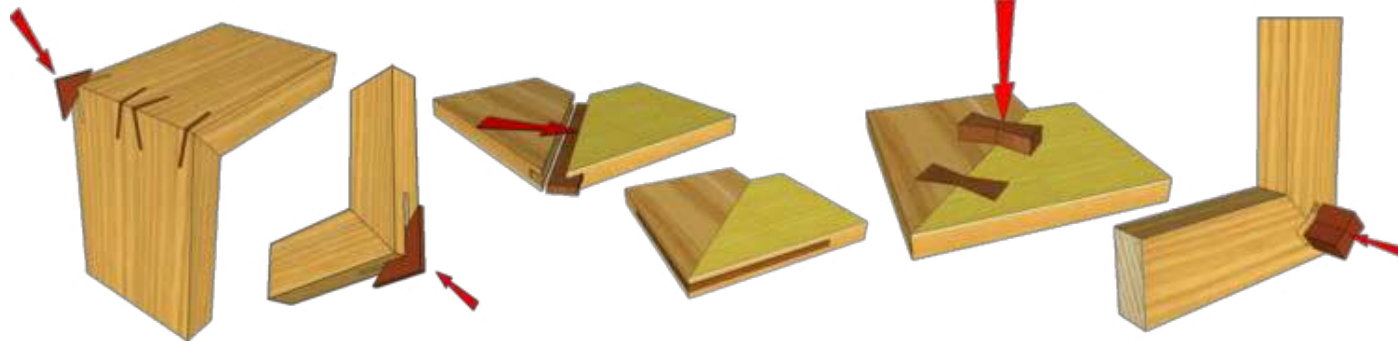
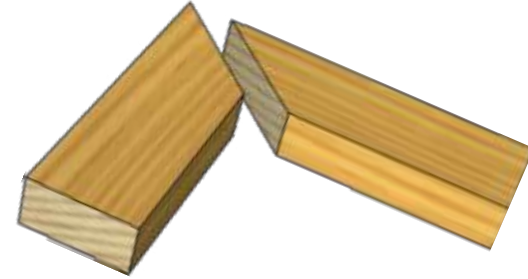

Corner Bridle Joint

The **corner bridle joint** (also known as a **slot mortise and tenon**) joins two members at their respective ends, forming a corner. This form of the joint is commonly used to house a rail in uprights, such as legs.

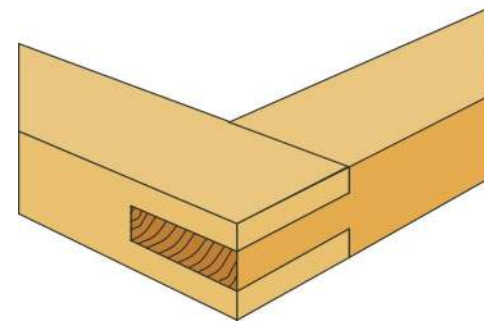

T Joints

Cross Halving Joint

This joint is very similar to the corner halving. It is stronger than the butt joint and is also simple to make, but still needs strengthening with screws or dowels.

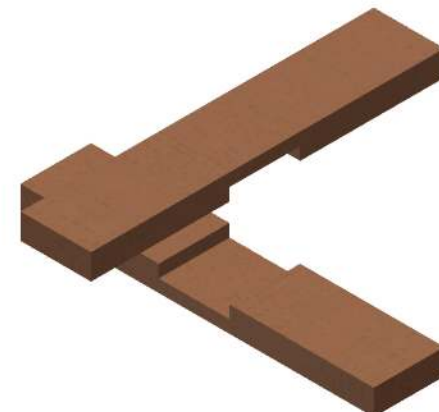

Jack Plane

The Jack Plane is used for producing smooth flat surfaces and edges on wood. The overall length of the jack plane is 250mm and the cutting iron (this is the blade that shaves the wood) is either 50mm or 60mm wide.



Smoothing Plane

This plane could be regarded as being the smaller brother of the Jack Plane. It is used for cleaning up and removing all tool marks on the work piece.



Constituent parts of a Smoothing Plane



Auger Bit

For boring deep holes in wood. The tang of the bit is square to allow fitting into the ratchet brace.



Flat Bit

These bits are used in electrical drills for fast, accurate drilling in both soft and hard woods.



Forstner Bit

This bit is used for drilling shallow, flat bottomed holes in wood. The bit is guided by its rim and not by a centre point as with the flat and auger bits.



Twist Drill

This type of drill can drill holes in wood, plastics and metals. Common sizes are 1mm to 13mm.



Rebate Plane

This type of plane is generally used to make a REBATE on the edge of a piece of wood as can be seen from the picture opposite. It can use a number of different interchangeable blades which allow different types of cut to be made to the edge of the wood.



Typical cut made by a Rebate Plane

T Dovetail Joint

A **Dovetail Joint** or simply **dovetail** is a joinery technique most commonly used in woodworking joinery (carpentry) including furniture, cabinets, carcass construction, log buildings and traditional timber framing. Noted for its resistance to being pulled apart (tensile strength), the dovetail joint is commonly used to join the sides of a drawer to the front.

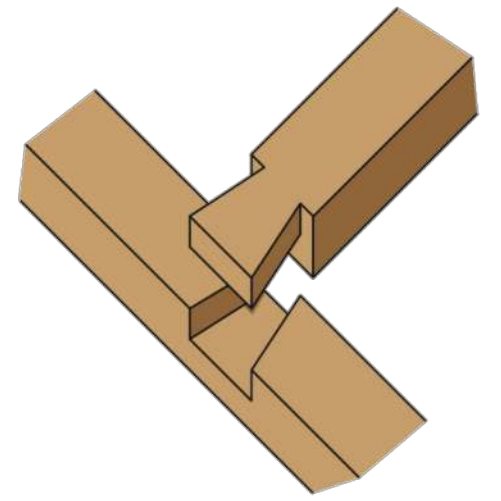

Through Mortise & Tenon Joint

The mortise & tenon joint is the strongest tee joint and can be further strengthened by wedging or dowelling.

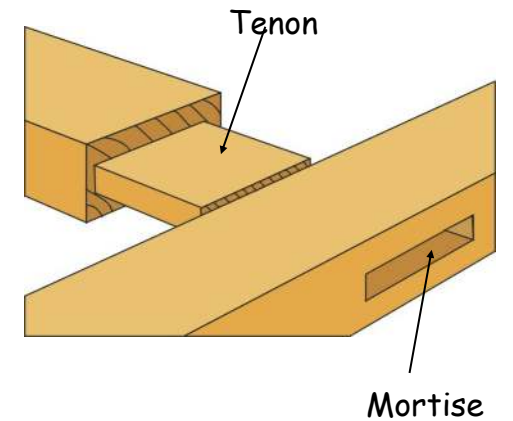

Stub/Stopped Mortise & Tenon

This joint is very similar to a through mortise and tenon joint except the stub does not go all the way through

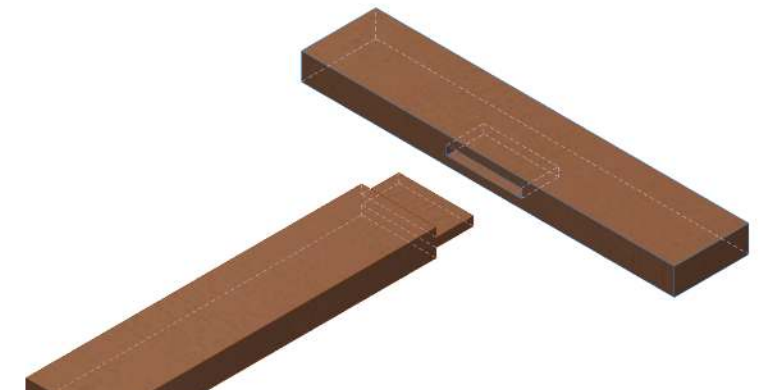

T Bridle

This joint is similar to a mortise and tenon joint. This form of the joint is commonly used to house a rail in uprights, such as legs. It provides good strength in compression. The bridle joint is very popular in workbench construction.

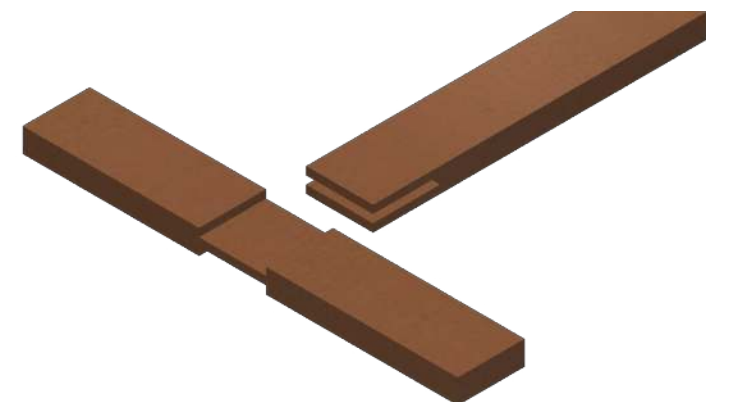

Carcass Joints

Corner Dovetail Joint

This type of joint is very strong and can be only pulled apart in one direction. It is used to construct drawers.

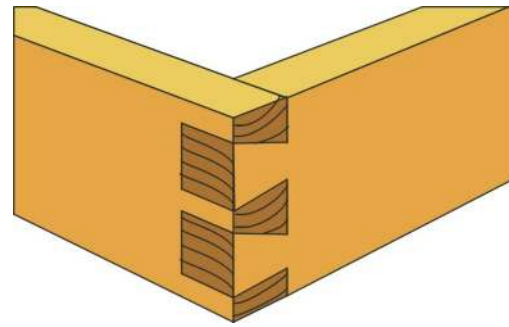

Lapped Dovetail Joint

The Lapped Dovetail Joint is used in cabinet construction where the dovetail joint is used for strength but should not be seen from one side.

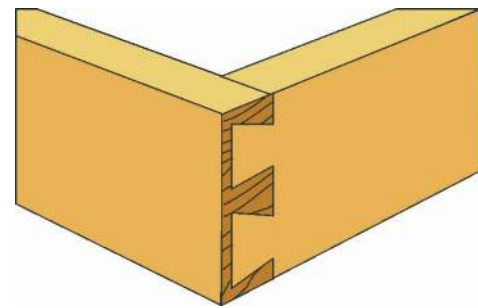

Stopped Housing

These are harder to make, but are neater because the joint does not show on the front edge.

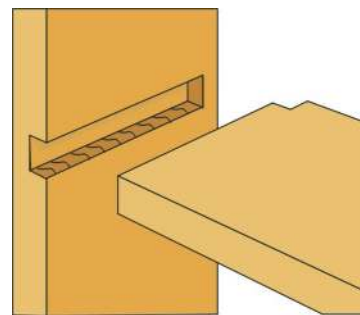

Through Housing

These joints are simple to make and are suitable where the two parts being joined together are the same width.

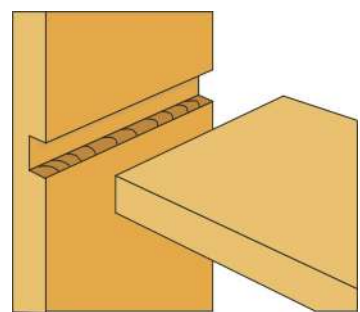

Corner Rebate Joint

The rebate joint is a very similar woodwork joint to the butt joint but the big difference between the two is that one of the ends of the timber has a groove cut out of it to create much better holding strength.

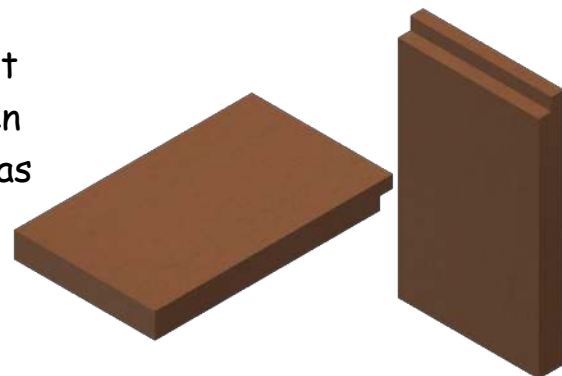

Outside Calliper

An outside calliper is a device used to measure the distance between two opposite sides of an object. The tips of the calliper are adjusted to fit across the points to be measured, the calliper is then removed and the distance read by measuring between the tips with a measuring tool, such as a steel rule.



Inside Calliper

An inside calliper is a device used to measure the distance between two opposite sides of an object. The tips of the calliper are adjusted to fit inside the two faces to be measured, the calliper is then removed and the distance read by measuring between the outside tips with a measuring tool, such as a steel rule.



Pliers

This tool is mainly used to grip small items but can also cut wire.



Saw Board

The use of the saw board prevents the workbench from being damaged by continual cutting. It also allows timber to be held in a steady position whilst cutting is taking place.



Long Nose Pliers

This tool is an adaptation of the pliers above except it has long narrow jaws which allow it to get into tight spaces.



Boxwood Mallet

These mallets have a cylindrical head mallet of high density wood such as **Lignum Vitae** or **Boxwood**, with a resilient, shock absorbing cane handle.

Used by **Tinsmiths** to fold and bend edges of **Tinplate**.



Steel Rule

A simple device used to measure, usually always in mm.

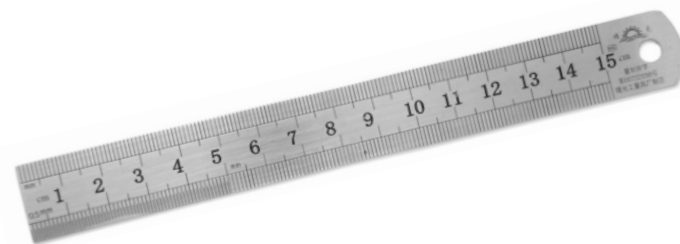

Measuring Tape

The measuring tape does the same job as the steel rule expect it is substantially longer. They can be as long as 30m.



Dovetail Template

A Dovetail Template is used to draw around for making a dovetail joint.

The right hand image is a card template that would get folded around the end of the piece of timber. The joints would then be drawn around on the top and bottom of the timber.

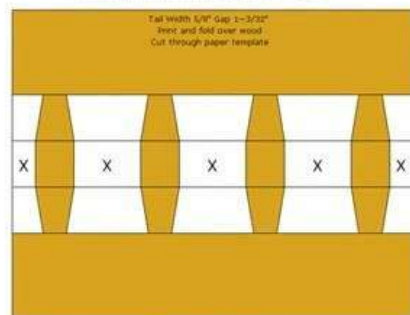

Carpenters' Mallet

The carpenters' mallet is used in woodwork for hitting chisels or for assembling parts of wood together.

The carpenters' mallet is made from a hardwood called beech as this wood is very hard wearing.



Surface Preparation & Finishing

Sanding

You should always sand in the direction of the grain where possible for a smooth finish and remove all sanding dust using a cloth before applying a finish. Wrap sandpaper around a sanding block when sanding flat surfaces.



Look out for dried glue, especially around joints. If not thoroughly removed during sanding it will interfere with the finishing process.

End-grains (areas where the wood has been cut against the grain), tend to soak up more finish than surfaces cut with the grain. Additional sanding to end-grain areas gives better absorption of finishes.

To sand turned pieces wrap a strip of sandpaper around the piece and work it back and forth like dental floss.

For bigger jobs, use a power sander, but first practice on a spare piece of wood.

To check your work, run a sock over the sanded wood. If it snags, you'll need to re-sand the area.



Sand Paper/Glasspaper

Sandpaper or **Glasspaper** are names used for a type of coated abrasive that consists of sheets of paper or cloth with abrasive material glued to one face. Despite the use of the names neither sand nor glass are now used in the manufacture of these products as they have been replaced by other abrasives such as aluminium oxide or silicon carbide.

Sandpaper is produced in a range of grit sizes and is used to remove material from surfaces, either to make them smoother (for example, in painting and wood finishing), to remove a layer of material (such as old paint), or sometimes to make the surface rougher (for example, as a preparation for gluing).

It is common to use the name of the abrasive when describing the paper, e.g. "aluminium oxide paper", or "silicon carbide paper".

The grit size of sandpaper is usually stated as a number that is inversely related to the particle size. A small number such as 20 or 40 indicates a coarse grit, while a large number such as 1500 indicates a very fine grit. In the technical department we tend to use P60 - P400.



Filling

Wood stopping or filler can be used to fill small holes, cracks and gaps in unfinished wood. Once applied and dried it can be drilled, sanded, planed and filed like wood.

Method

Sand the area with fine grit sandpaper to remove any rough spots of filler above the surface of the wood then clean the excess dust off of the area with a damp cloth.

If you will be staining the wood, make sure the wood filler chosen is suitable for staining.

Spread the filler onto the area. Use a putty knife and press it in tightly. Do not make the putty completely flush as it will shrink as it dries. Allow for the filler to dry. Rub the area with a fine sandpaper. A second coat of filler maybe required. Repeat the operation until satisfied.

Now apply a suitable paint, stain or wax to your model. See overleaf for correct procedure.



Rasps

A rasp is used for rough shaping of wood and other soft materials. The most commonly shaped rasp is the half round. As can be seen from the close up the teeth are much bigger than a file.



Sliding Bevel

Used to mark out lines on wood at an angle to a given surface on wood.

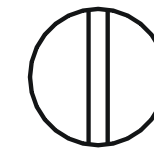

← Slotted Screw Head

Screwdriver (straight slot)

This type of screwdriver is used to drive slotted screws into wood. The main disadvantage of its use is that it can slip out of a straight slot and damage both the head of the screw and the wood.



← Phillips Screw Head

Phillips Screwdriver

The main advantage of the Phillips slot is that the screwdriver blades do not slip.



Hand Drill or Wheel Brace

The hand drill or as it otherwise known, the wheel brace is used to drill holes up to a diameter of 8mm. If the hole to be drilled is close to an edge the handle can be removed to allow the drill to get close in.



Bradawl

This is used for making small holes in wood prior to starting to insert a screw.



Mortise Gauge

This tool is very similar to the marking gauge but this gauge marks two parallel lines opposed to the marking gauges one line. It is ideal for the marking out of mortise and bridle joints.

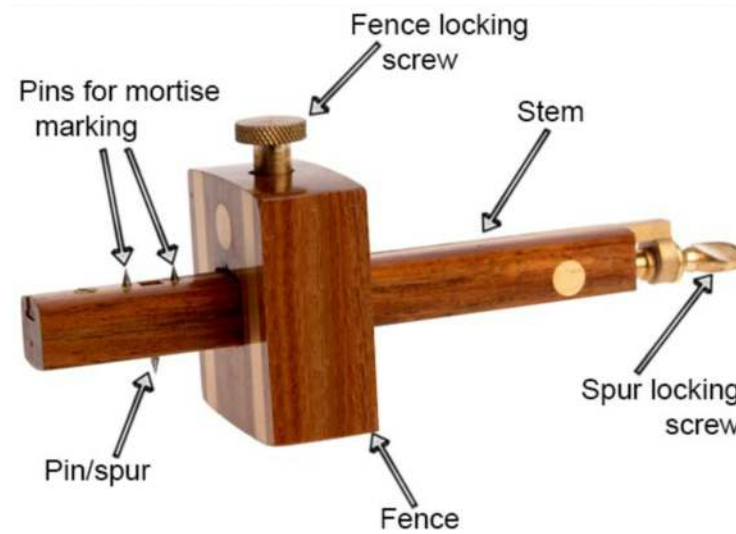

Marking Knife

The marking knife is used to mark lines on wood, usually across the grain. A knife cuts a thinner more accurate line than a pencil. It is nearly always used with a try square.



Applying a Finish

Before applying a finish it is important to make sure that the surface is very smooth and free from blemishes (marks and scratches) by firstly using an appropriate plane or scraper and then different grades of abrasive paper in the direction of the grain.

Sequence to applying varnish to a piece of wood

1. The **Smoothing Plane** (Smaller brother of the Jack Plane) is used first to remove pencil lines and any major blemishes.
2. Next, use a **Medium grade** of glass paper sand all surfaces.
3. The next stage is to apply a fine sprinkle of water over the surface of the wood. This raises the grains in the wood which when dry will be sanded off using a **Fine Graded** glass paper. This technique gives a better overall finish.
4. Using a **Fine Graded** glass paper sand down all surfaces.
5. Apply first coat of varnish. Allow to dry.
6. Using a **Fine Graded** glass paper sand down all surfaces.
7. Apply second coat of varnish. Allow to dry.

Types of finish available

- Water Based Varnish
- Spirit Based Varnish
- Wax Polish
- Coloured Wax Polish
- Danish Oil
- Coloured Stains
- Paints
- Linseed Oil
- Vegetable Oil



Scraping Wood

Scrapers are an alternative to sandpaper as they give smoother results than sandpaper. It is good to use sandpaper throughout the building process, but for final smoothing it is recommended to scrape the wood clean and flat.



Recycling & Sustainability

Ways to work sustainability in Practical Woodworking:

- Use FSC (Forrest Stewardship Council) certified timber. FSC runs a global forest certification system which allows consumers to identify, purchase and use wood, paper and other forest products produced from well-managed forests and/or recycled materials.
- Select wood appropriate for your piece - can recycled or FSC certified wood be used instead of a less sustainable timber?
- Not using tropical hardwoods like mahogany unless recycled.
- Always turn the extraction on when using woodworking machinery. As well as being a good health and safety measure sawdust can be used for producing; particleboard, mulch fuel blocks.
- Putting scrap wood that is large enough to be used again in the scrap wood pile not the bin.



Mitre Square

This is used to mark out angles of 45 degrees and 135 degrees and for testing mitres. It is used the same way a Try Square is used except it checks different angles.

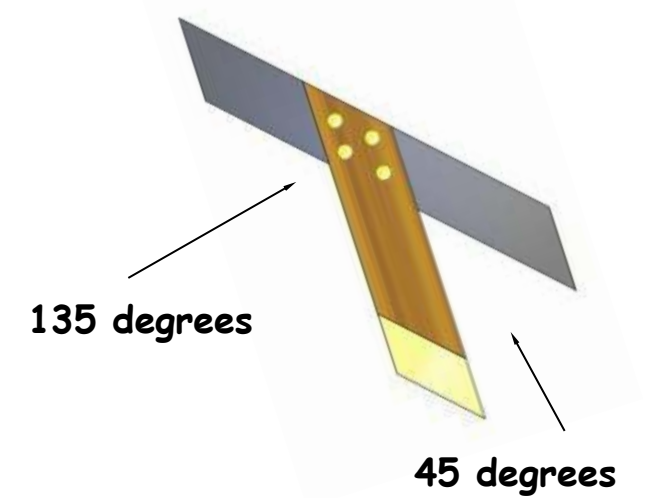

Cutting Gauge

This type of gauge is very similar to the marking gauge except it has a cutting blade instead of a spur. It is ideal for cutting end grain or veneers.



Dovetail Saw

A Dovetail saw is very similar to the Tenon saw except the teeth of this saw are much smaller allowing more accurate cuts. As the name implies it is an ideal saw for cutting dovetail joints.



Pad Saw

The Pad saw is used for cutting straight and curved cuts in the middle of a piece of wood. i.e. where other saws cannot reach.



Surform Tools

These are a type of file with large teeth. There is a hole behind each tooth which allows any filings to escape and thus reducing clogging. The most commonly use shape used are the flat and round surforms.



Parts of a Bevel Edge Chisel

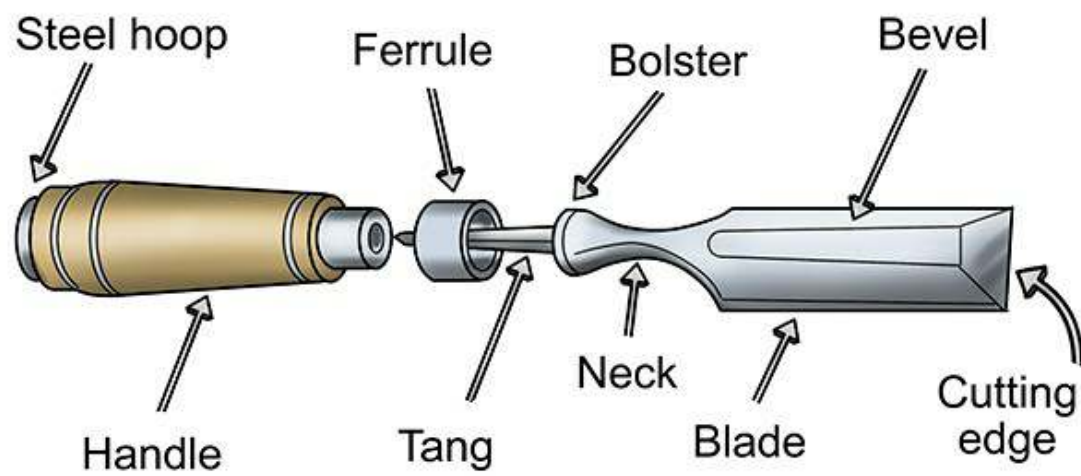

Mortise Chisel

As the name suggests this chisel is used to cut out the mortise in a Mortise and Tenon joint. It is a stronger chisel than the bevel edged chisel. This allows it to be struck with a mallet and has a shock absorbing leather washer between the handle and the blade.



Bevel Edged Chisel

The bevel edged chisel is used for paring and general chiselling of wood. Two edges of the blade are bevelled along their length and this makes it suitable for accurate joint work. The size of the chisel is indicated by the width of the blade (3mm - 50mm).

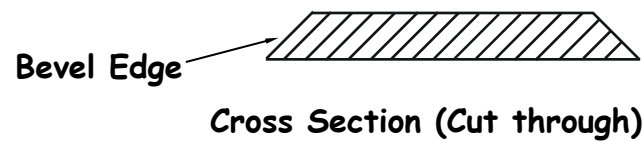

Firmer Chisel

This type of chisel is used for general chiselling work. As its name implies, it is firmer than the bevel edge chisel.

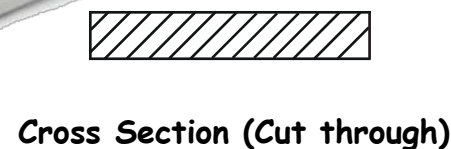

Safety Note

When working with the bevel edge chisel or any type of wood chisel **ALWAYS** keep both hands behind the cutting edge.

Gluing up Frames

Before any gluing of frames can be carried out, the frame must be assembled **DRY**. i.e. it needs to be checked to ensure that it is **Square** and is not affected by Winding (Twisting of the frame). To check if the frame is square it is ideally done using long straight sticks to check the diagonals. See below.

Table Frame

As can be seen from the drawing opposite, if a frame construction is **Square**, the diagonal distance (Corner to Corner) between each corner will be the same distance.

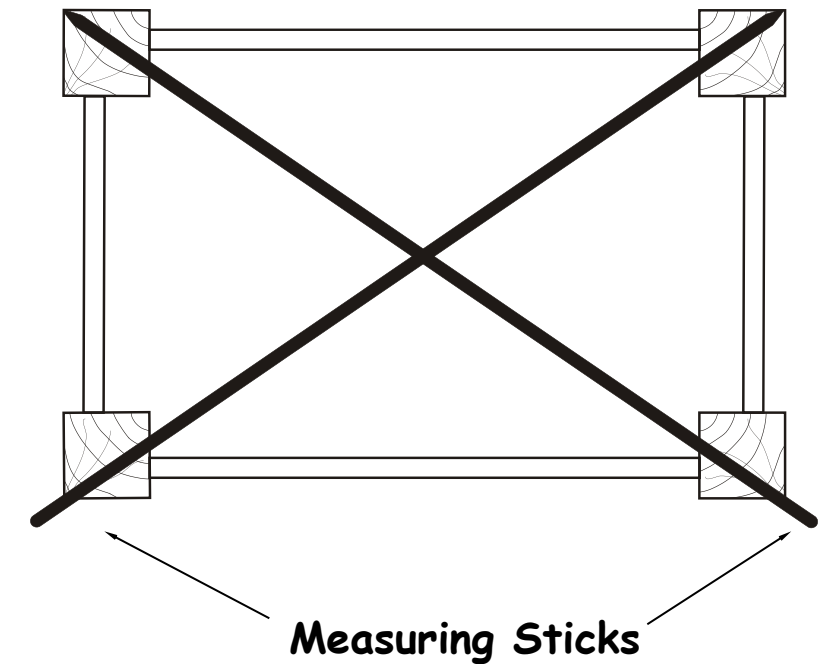

If the frame is not square the diagonal distance from corner to corner will be greater for one of the corners as shown opposite. This is corrected simply by adjusting the sash cramps until a satisfactory squareness is achieved.

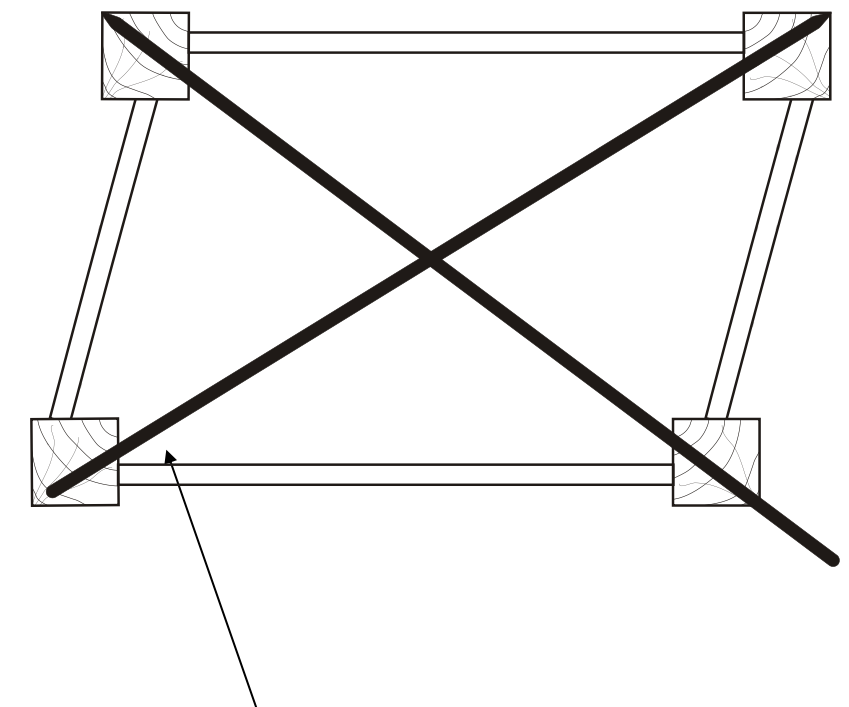

Diagonal much longer than opposite diagonal

Dry Clamping

Dry clamping consists of clamping up your model without applying glue. The reason for this is to ensure everything fits together before the gluing. Any defects/anomalies can be rectified prior to the final assembly with glue.



Cramping

String and Block

This technique is used for clamping up wooden frames like the one shown below. Wooden blocks are placed at each of the corners as shown below. A length of string is then wrapped around the frame tightly and then a knot is tied to keep the frame tight whilst the glue dries.

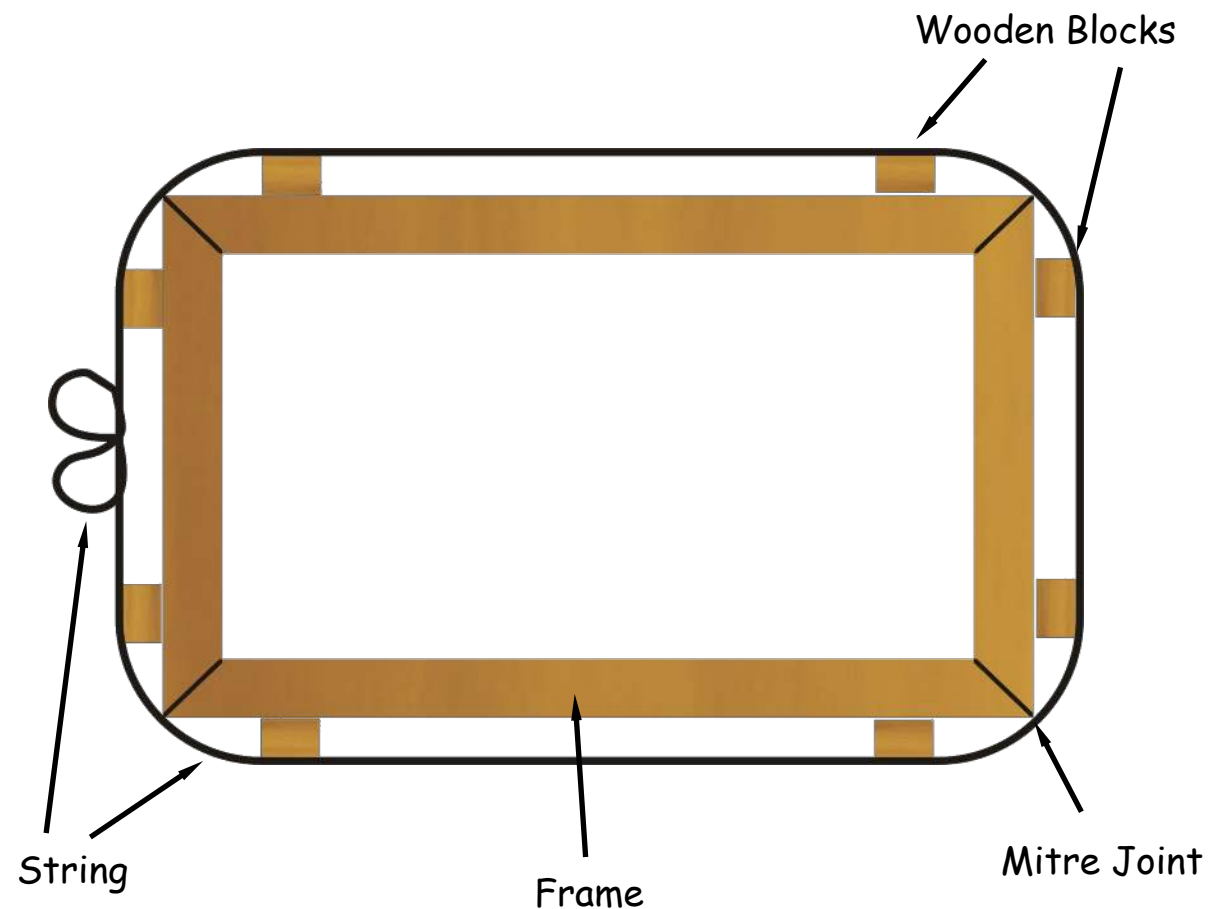

Woodworkers Bench Vice

This vice is fixed to the bench so that the top of the wooden jaw facing the bench is level with the top of the bench, it is used for holding wood.



Coping Saw

The coping saw is used to cut curves and other awkward cuts in wood. It is also unique as it is one of only a few saws which has its teeth facing backwards. In normal sawing the cut is made in the forward stroke but with the coping saw the cut is made on the backward stroke.



Fret Saw

A Fret saw is very similar to the Coping saw except it can be used for even more intricate and deeper cuts than that of the coping saw.



Panel Saw

The panel saw is a fine toothed crosscut for sawing plywood, thin wood and large joints.



Cross-Cut Saw

This type of saw is used for cutting **across** the grain of large piece of wood. The sketch opposite shows the teeth of this type of saw.

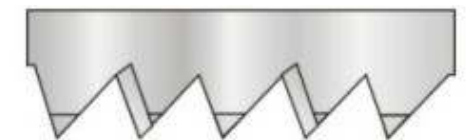

Rip-Saw

The Rip saw is used for sawing **along** the grain of large pieces of wood.

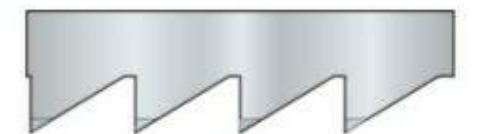

Try Square

The try square is used to test the squareness of material and mark out lines at **right angles** to a given surface on wood or plastic. The stock is made from rosewood with a tool steel blade.

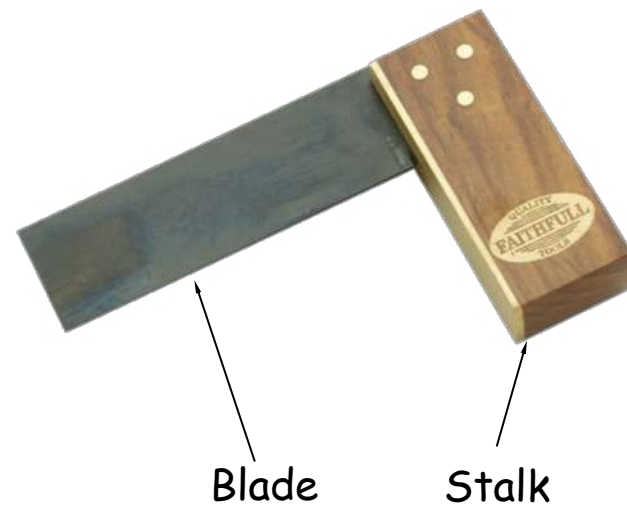

Marking Gauge

The marking gauge is used for marking lines **parallel** to an edge on timber (cut wood). The stock and stem are made from beech because beech is a very hard wearing wood, whilst the spur is made from steel sharpened to a point. The thumbscrew is made from plastic or box wood and then threaded into the stock.

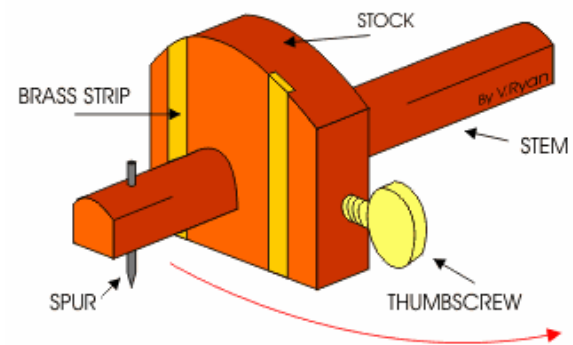

Pincers

Pincers pull out nails which the claw hammer cannot grip, either because they are too small or do not have a head. The small thin claw on the handle of the pincers will fit under the heads of small nails and lever them out far enough for the pincers to grip



Nail Punch

There are different sizes of nail punch to suit different sizes of nail. They are used to drive headless nails and panel pins below the surface, so that the hole can be filled with a suitable wood filler.

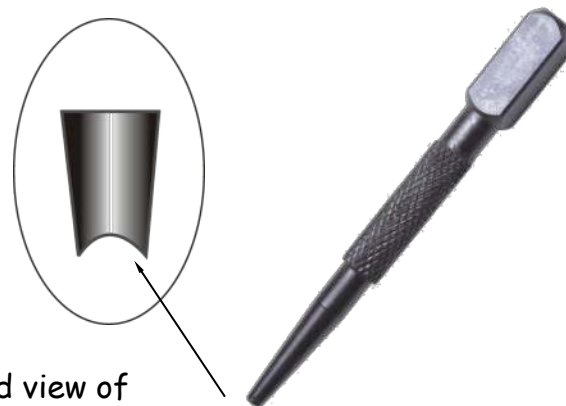

G Cramp

This is used to hold work down onto a bench and to cramp small pieces of glued wood together.



Sash Cramp

This cramp is used to hold frames, carcasses and butt joints while the glue sets. Always ensure that the wood being cramped is protected from damage by using scrap pieces of wood between the cramp and the frame/carcass being cramped.

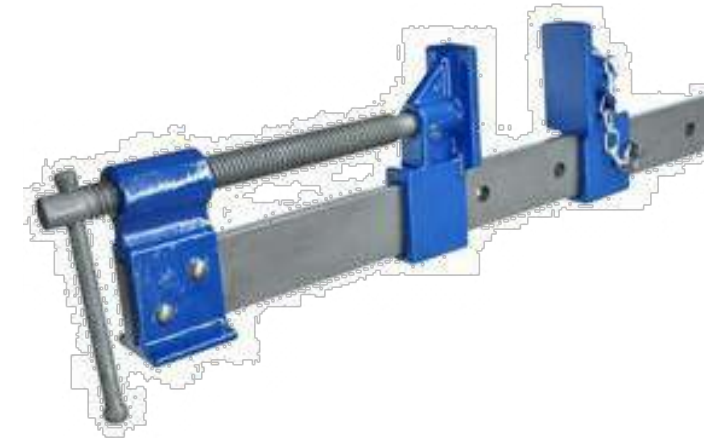

Mitre Cramp

Mitre clamps are designed to hold mitre joints together. The right angled plates are higher than the screws and the red holder. The screws go under the frame (work-piece) to be held, and the red bit clamps down on the lower-edge of the frame.

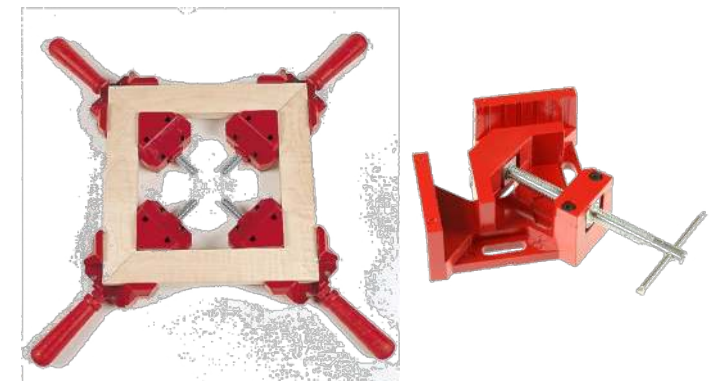

Band Cramp

A **band cramp** (also known as a **web cramp**) is a type of clamp that allows the clamping of items where the surfaces to be clamped are not parallel to each other; where there are multiple surfaces involved; or where clamping pressure is required from multiple directions at once



Woodworking Tools

The Ratchet Brace

The ratchet brace is used to hold and turn various boring bits when cutting circular holes in timber. The head of the brace rotates on a ball bearing washer to reduce friction. The other end of the crank has a chuck containing "alligator" jaws which hold the bit. The chuck is attached to the brace by means of a threaded core at the end of the crank. The ratchet enables the brace to be used in a confined space where it would be impossible to make a complete revolution of the crank. The sweep of the crank is usually about 250mm.



PVA Glue

Polyvinyl acetate (PVA) is probably the most common type of wood glue used in the school workshop. It is a white water based liquid adhesive (i.e. it is mainly made of water). It is supplied to schools in plastic containers. It is easy to apply, non-staining (although excess glue should be wiped off with a damp paper towel) strong and attains its maximum strength usually after twelve hours. If a wood glue is required for external use a waterproof PVA glue must then be used.



Claw Hammer

This hammer is used for heavy nailing (i.e. used for hammering big nails). The claw part of the hammer is used to remove nails that have already been driven into the wood.



Cross Pein Hammer

This is a very light weight hammer with a cross pein at one end. This hammer is used for light work with the cross Pein part being used to start driving short nails and panel pins into the wood. The shaft of the hammer is made from a special wood called Hickory. The reason for using hickory is because it is a very tough wood and therefore less likely to break when being used.

Cross Pein



Tenon Saw

The Tenon Saw is used for general sawing in wood. The fine teeth 12 - 14 per 25mm ensure a fine saw cut or KERF. To help prevent the saw blade jamming when sawing the teeth are SET, i.e. the first tooth is bent to the right and the second to the left and then right and so on. The purpose of this is to make a bigger gap than the thickness of the blade, this will allow the blade to cut without jamming. Your teacher will demonstrate what this means. The Tenon Saw has a brass or steel Stiffening Rib to strengthen the back of the blade and prevent it from being too flexible.

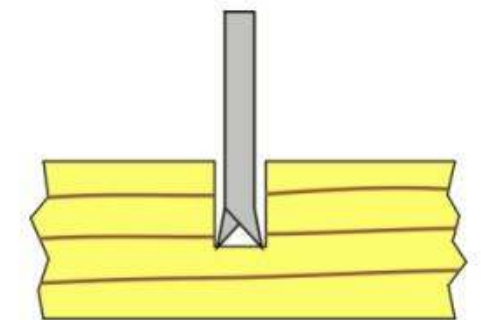

Kerf

Hole Saw

This tool is used to drill big holes in wood and is generally fitted to an electric drill. The hole saw has a centre drill attached which is called the PILOT drill. It is called this because it ensures the hole saw makes a hole exactly where you want it.

